

STAINLESS STEEL WAFER SPRING CHECK VALVE PN40



Certificate 3.1

Size : DN 15 to DN200
Ends : Between flanges PN10/16/25/40 and Class 150
Min Temperature : - 20°C
Max Temperature : + 200°C
Max Pressure : 40 Bars
Specifications : Spring type
All positions
Metal / metal

Materials : Stainless steel ASTM A351 CF8M

STAINLESS STEEL WAFER SPRING CHECK VALVE PN40
SPECIFICATIONS :

- Spring type
- All positions (respect the flow direction indicated by the arrow)
- Short length
- Disc rib guide for a better centering
- Full stainless steel corrosion resistant and for high temperature
- Metal / metal tightness
- With guide from DN125 to 200

USE :

- Chemical and pharmaceutical industries, petrochemical industries, hydraulic installation, compressed air
- Min Temperature Ts : - 20°C
- Max Temperature Ts :+ 200°C
- Max Pressure Ps : 40 bars (see graph under)
- Steam : 14 bars max

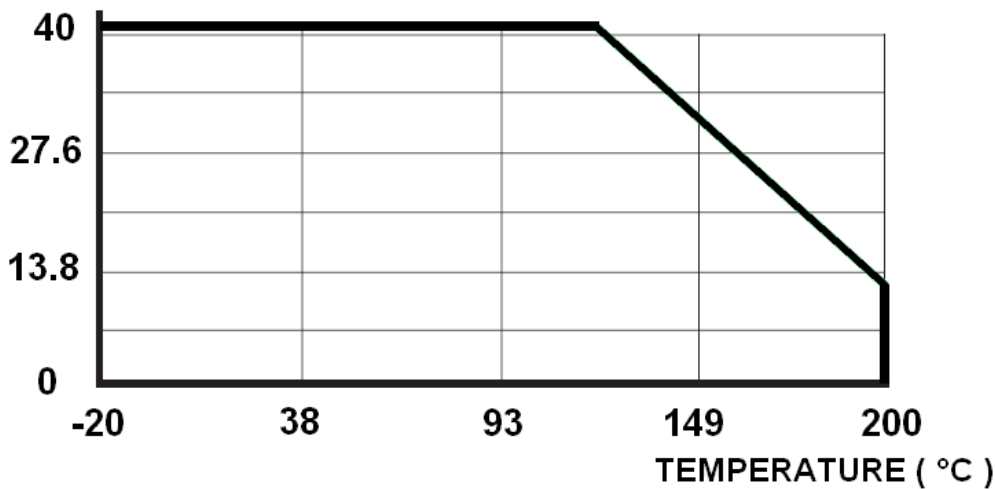
PRESSURE / TEMPERATURE GRAPH (STEAM EXCLUDED)DN15-100 :
PRESSURE
(Bar)

PRESSURE / TEMPERATURE RELATION DN125-200 :

| Pressure (Bar) | 39.2 | 38 | 33.3 | 30.4 | 28.2 |
|------------------|------|----|------|------|------|
| Temperature (°C) | -10 | 50 | 100 | 150 | 200 |

FLOW COEFFICIENT Kvs (M3 / h) :

| DN | 15 | 20 | 25 | 32 | 40 | 50 | 65 | 80 | 100 | 125 | 150 | 200 |
|--------------|-----|------|-----|------|------|------|------|-------|------|-----|-----|-----|
| Kvs (m3/h) | 2.1 | 5.76 | 9.6 | 14.5 | 21.9 | 24.2 | 57.1 | 64.97 | 90.2 | 228 | 809 | 647 |

STAINLESS STEEL WAFER SPRING CHECK VALVE PN40

RANGE :

- Between PN10/16/25/40 flanges and Class 150 (PN20)** **Ref. 386** from DN15 to DN100
 - (*) : For an installation between flanges PN10/16 for DN100, we only use 4 bolts
 - (**) : For an installation between flanges Class 150 (PN20) for DN25, DN32 and DN40, use 4 bolts M12
- Between PN40 flanges and **Ref. 386** from DN125 to DN200

HEAD LOSS GRAPH :

Flow (m³/h)

Flow (l/s)

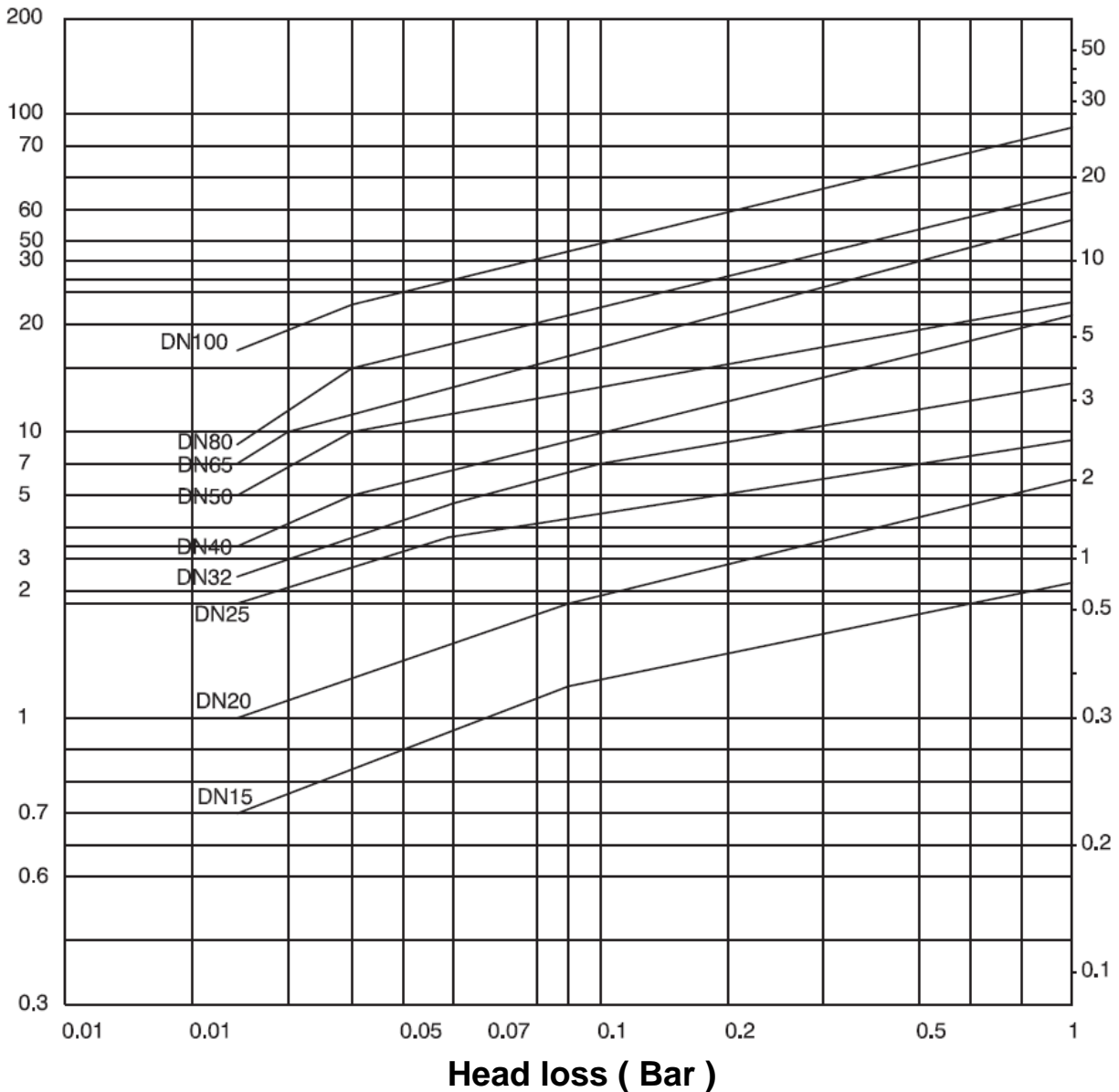

STAINLESS STEEL WAFER SPRING CHECK VALVE PN40

LEAKAGE RATE ACCORDING TO API 598 (DURING 60s excepted for DN200: 120s):

| DN | 8 | 10 | 15 | 20 | 25 | 32 | 40 | 50 | 65 | 80 | 100 | 125 | 150 | 200 |
|------------------------|------|----|----|----|----|----|----|----|------|------|------|------|------|------|
| Liquid Test (cc/min) | 6 | | | | | | | | 7.5 | 9 | 12 | 15 | 18 | 24 |
| Gas Test (m3/h) | 0.08 | | | | | | | | 0.11 | 0.13 | 0.17 | 0.21 | 0.25 | 0.34 |

OPENING PRESSURE (in mbar) :

| DN | Vertical Position Ascending Fluid | Horizontal Position |
|--------|--------------------------------------|---------------------|
| DN 15 | 25 ↑ | 23 → |
| DN 20 | 25 ↑ | 23 → |
| DN 25 | 25 ↑ | 23 → |
| DN 32 | 27 ↑ | 24 → |
| DN 40 | 29 ↑ | 25 → |
| DN 50 | 29 ↑ | 25 → |
| DN 65 | 31 ↑ | 25 → |
| DN 80 | 32 ↑ | 26 → |
| DN100 | 33 ↑ | 27 → |
| DN 125 | 60 ↑ | 51 → |
| DN 150 | 60 ↑ | 50 → |
| DN200 | 62 ↑ | 49 → |

STAINLESS STEEL WAFER SPRING CHECK VALVE PN40

MATERIALS :

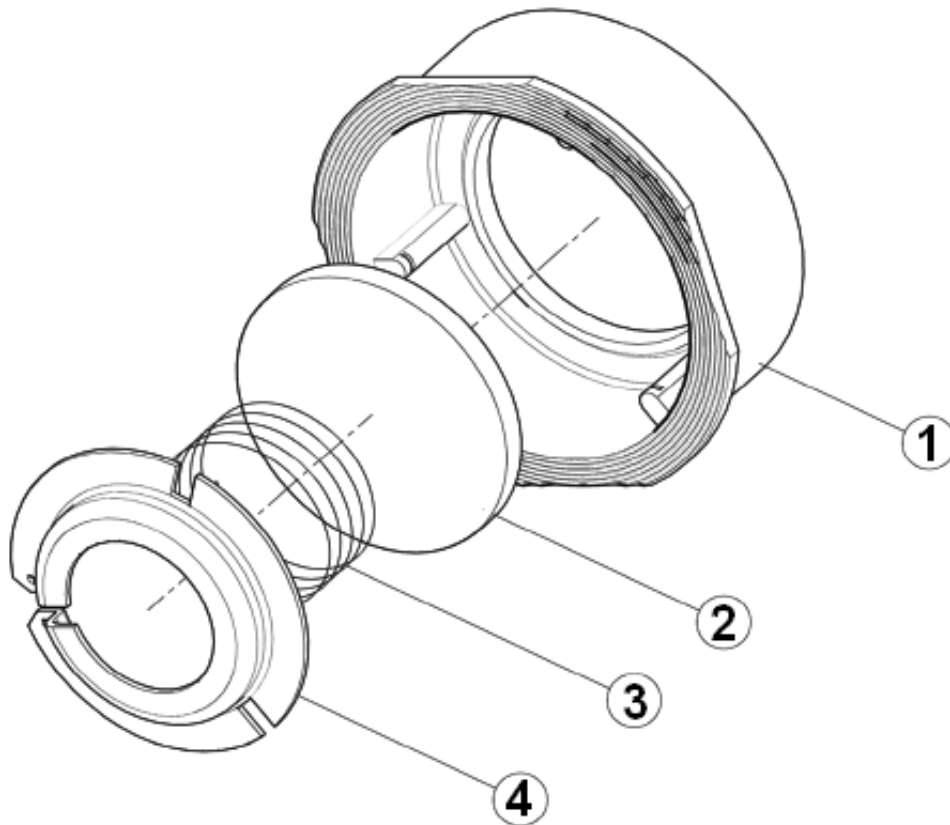

| Item | Designation | Materials |
|------|---------------|----------------|
| 1 | Body | ASTM A351 CF8M |
| 2 | Disc | ASTM A240-316 |
| 3 | Spring | AISI 316 |
| 4 | Spring holder | ASTM A240-316 |

STAINLESS STEEL WAFER SPRING CHECK VALVE PN40

SIZE (in mm) DN15-100 :

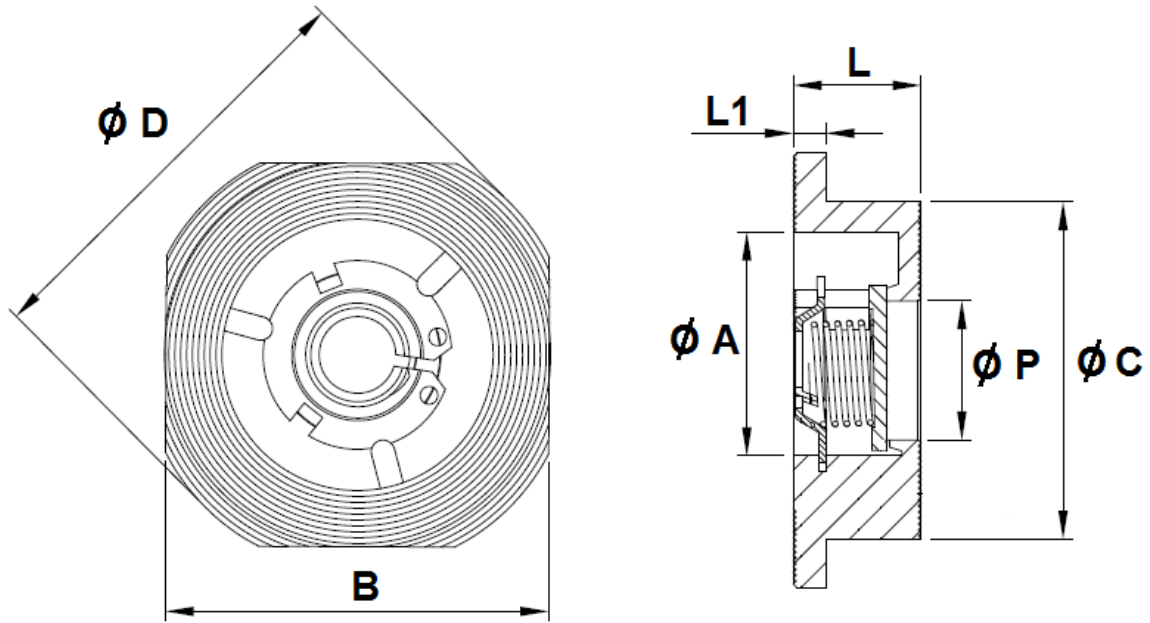

DN 15 – 80

DN100

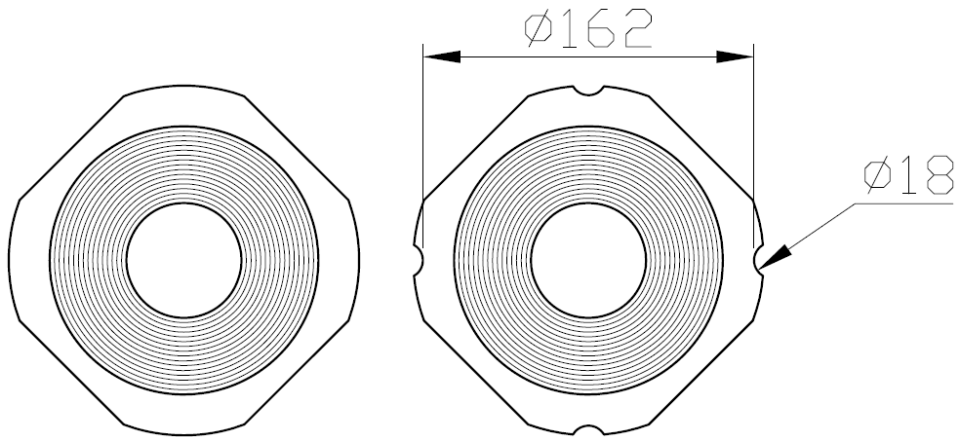

| Ref. | DN | 15 | 20 | 25 | 32 | 40 | 50 | 65 | 80 | 100 |
|------|-----------------|------|-----|-----|-----|------|-------|-------|-------|-------|
| 386 | $\varnothing A$ | 34 | 39 | 46 | 60 | 70 | 79 | 101 | 109 | 134 |
| | B | 44.6 | 54 | 65 | 78 | 88 | 101.6 | 120.4 | 133 | 164 |
| | $\varnothing C$ | 40.5 | 47 | 56 | 70 | 80 | 90 | 113 | 123 | 150 |
| | $\varnothing D$ | 54 | 62 | 73 | 83 | 93 | 107 | 126.5 | 141.2 | 171.4 |
| | L | 16 | 19 | 22 | 28 | 31.5 | 40 | 46 | 49 | 60 |
| | L1 | 3.5 | 3.5 | 4 | 5 | 5 | 5 | 5.5 | 5.5 | 6.5 |
| | $\varnothing P$ | 12.5 | 20 | 25 | 32 | 38 | 49 | 64 | 78 | 98 |
| | Weight (Kg) | 0.1 | 0.2 | 0.3 | 0.5 | 0.6 | 0.9 | 1.4 | 2 | 3 |

STAINLESS STEEL WAFER SPRING CHECK VALVE PN40

SIZE DN125-200 (in mm) :

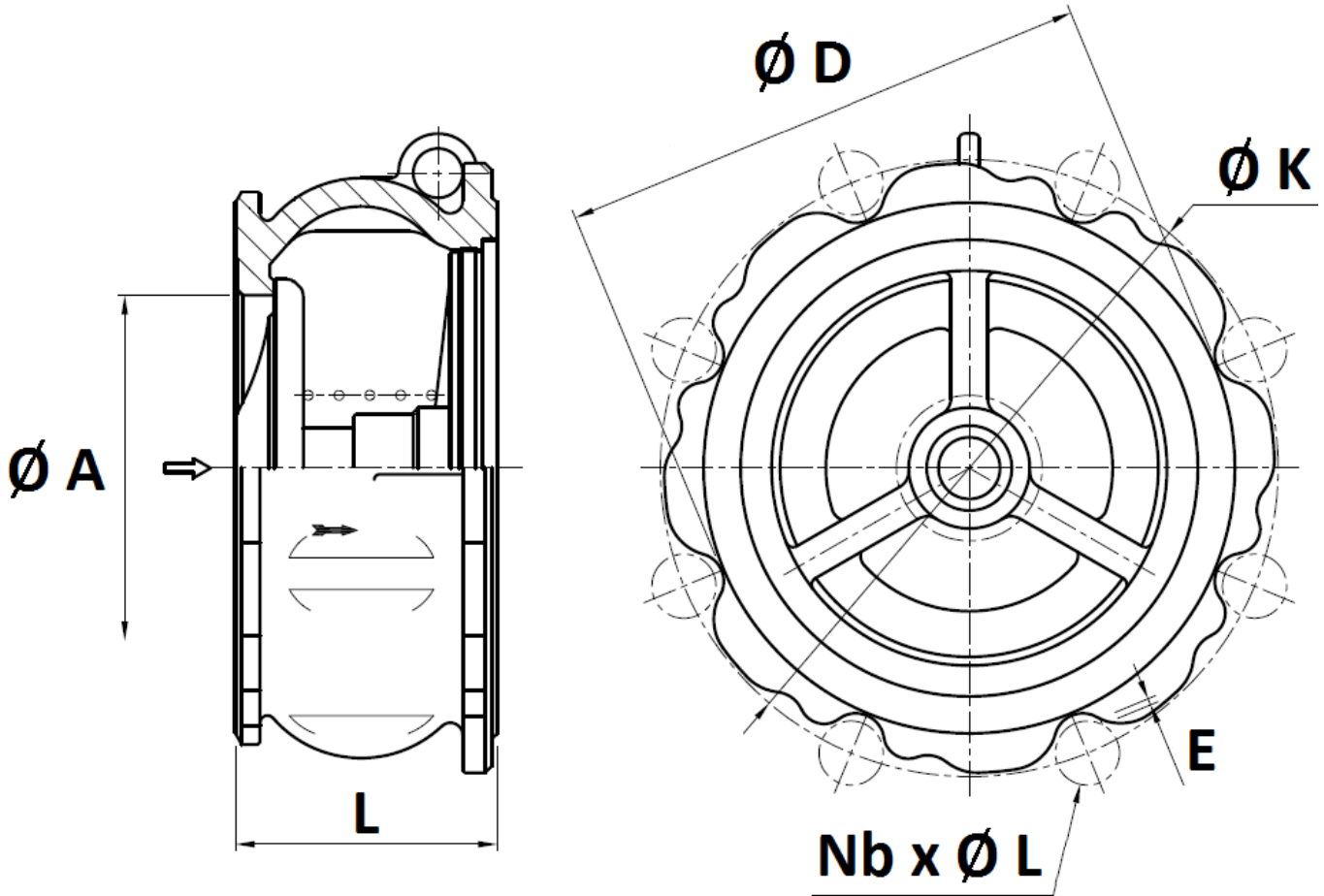

| Ref. | DN | 125 | 150 | 200 |
|------|----------------|--------|--------|---------|
| 386 | L | 90 | 106 | 140 |
| | Ø A | 120 | 140 | 184 |
| | Ø D | 186 | 216 | 267 |
| | Ø K | 220 | 250 | 320 |
| | Nb x Ø L | 8 x 26 | 8 x 26 | 12 x 30 |
| | E | 3 | 2.7 | 10 |
| | Weight (in Kg) | 8.34 | 13.4 | 24.2 |

STAINLESS STEEL WAFER SPRING CHECK VALVE PN40**STANDARDS :**

- Fabrication according to ISO 9001 : 2015
- DIRECTIVE 2014/68/EU : CE N° 0035 up to DN100, CE N°0062 from DN125 to 200
Risk Category III Module H
- Certificate 3.1 on request
- Designing according to EN 12516-1
- Pressure tests according to API 598, table 6
- Length according to EN 558 series 49 (DIN 3202 K4)
- ATEX Group II Category 2 G/2D Zone 1 & 21 Zone 2 & 22 (optional marking) **up to DN100**

ADVICE : Our opinion and our advice are not guaranteed and SFERACO shall not be liable for the consequences of damages.
The customer must check the right choice of the products with the real service conditions.

STAINLESS STEEL WAFER SPRING CHECK VALVE PN40

BOLTING POSTIONS :

- **BETWEEN PN10/16 FLANGES :**

DN 15 – 50

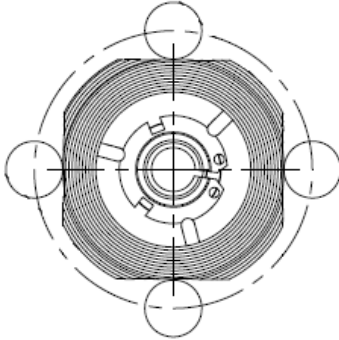

DN 65 – 80

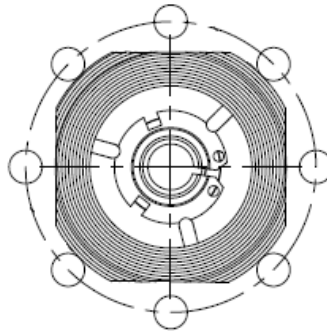

DN 100

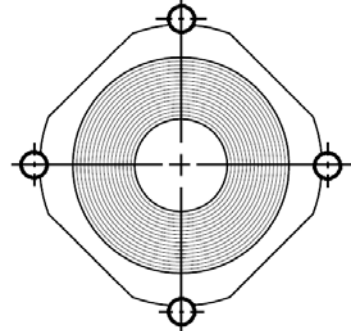

- **BETWEEN PN25/40 FLANGES :**

DN 15 – 50

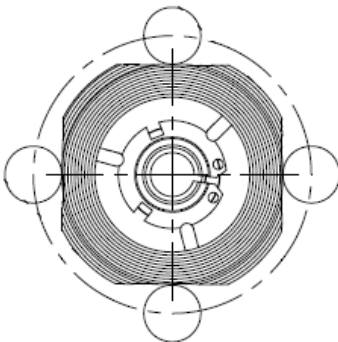

DN 65 – 100

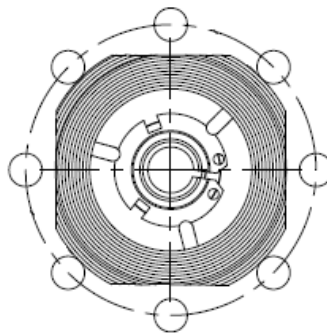

- **BETWEEN Class 150 PN20 FLANGES :**

DN 15 – 80

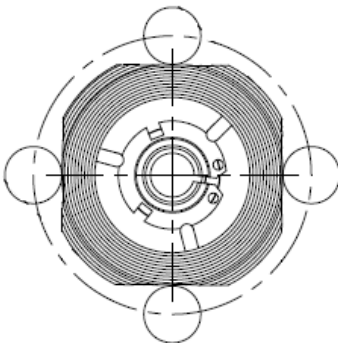

DN 100

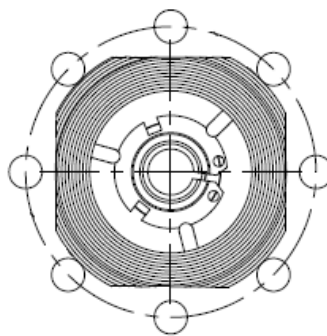

STAINLESS STEEL WAFER SPRING CHECK VALVE PN40**INSTALLATION INSTRUCTIONS****GENERAL GUIDELINES :**

- Ensure that the check valves to be used are appropriate for the conditions of the installation (type of fluid, pressure and temperature).
- Be sure to have enough valves to be able to isolate the sections of piping as well as the appropriate equipment for maintenance and repair.
- Ensure that the valves to be installed are of correct strength to be able to support the capacity of their usage.

INSTALLATION INSTRUCTIONS :

- **Before installing the check valves, clean and remove any objects from the pipes** (in particular bits of sealing and metal) which could obstruct and block the valves.
- **Ensure that both connecting pipes either side of the check valve (upstream and downstream) are aligned (if they're not, the valves may not work correctly).**
- **Make sure that the two sections of the pipe (upstream and downstream) match, the check valve unit will not absorb any gaps. Any distortions in the pipes may affect the tightness of the connection, the working of the check valve and can even cause a rupture.** To be sure, place the kit in position to ensure the assembling will work.
- Make sure there is enough space so that the disc can be opened totally in the pipe.
- If there is a direction changing or if there's another material, it's better to take away the check valve so that it is outside the turbulence area (**between 3 and 5 times the ND before and after**).
- After a pump please refer to **FD CEN/TR 13932** to install the check valve :
 - If it is essential to keep priming the pump, a non-return check valve can be fitted to the suction pipe at a distance **L1 (straight length suction) > 10xD1 (diameter suction)**
The check valve is designed to meet the maximum flow rate in service
 - In other cases, the non-return check valve is mounted on the discharge pipe at a distance of **L2 (straight length at discharge) > 3xD2 (diameter at discharge)**